

Portable Hose and Cable Reels

HANNAY REELS



**Hannay[®]
Reels**
The reel leader.

For use in:

- Industrial Maintenance
- Fire Protection/Rescue Operations
- On-site Repair
- Media Events/Entertainment
- Mobile Broadcasting
- Grounds Maintenance
- Power Tools and Lights
- Construction Sites

H-9421-POR
Rev. 6



Portable Storage Reels

Model C16-10-11

The model C16-10-11 portable cable storage reel is small, lightweight, and durable for quick and easy use—especially in fire/rescue, mobile broadcasting, or industrial maintenance and repair applications where long lengths of cable are payed out over large areas. This reel is supplied with a cam lock brake.

Model C20-14-16

Model C20-14-16 is a strong, portable reel for storing higher capacities. Steel construction with direct crank rewind for fast, easy pickup. Adjustable friction brake is used to brake the reel. An optional pin lock is available at additional cost.

Rewind:

Models C16-10-11 and C20-14-16 feature crank rewind handles permanently attached to the disc. Insert cable in opening in drum and disc to initiate winding.

NOTE: THESE STORAGE REELS HAVE NO LIVE CONNECTIONS.



For:

- Broadcast Cable
- Extension Cord
- Rope

Model C16-10-11



For:

- Broadcast Cable
- Extension Cord
- Forestry Fire Hose
- Rope

Model C20-14-16

Dimensions and capacities

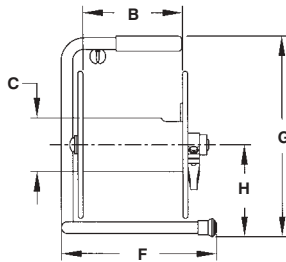

Model C16-10-11

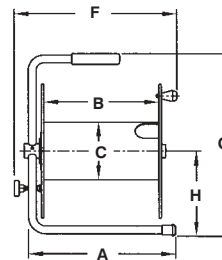
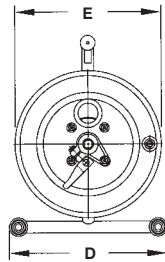

Model C20-14-16

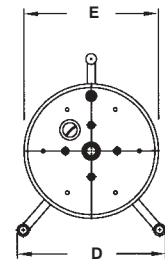

BE SURE TO CHECK DIMENSIONS AND WEIGHTS PRIOR TO ORDERING.

To receive a detailed parts breakdown drawing for Model C16-10-11, request ISO 88, for Model C20-14-16, request ISO 121.

Cable Capacity of Reel			Model Number	Reel Dimensions								Approx. Weight			
feet m.				inches mm.								lb. kg.			
Gauge/Number of Conductors			1" collapsible hose	A	B	C	D	E	F	G	H	NET	SHIP		
16/3	14/3	12/3													
O.D. (in)	.39	.53	.60												
O.D. (mm)	10.0	14.0	15.0												
	275	125	100	—	C16-10-11	—	7.5	4.5	11.88	10.75	11.75	15	6.88	10	13*
	84	38	30	—		—	191	114	302	273	298	381	175	5	6
	—	350	250	100	C20-14-16	15	12	6	15.5	14	16.75	19	8.62	18	30*
	—	107	76	30		381	305	152	394	356	425	483	219	8	14

Specifications subject to change.

*When shipped as parcel package (via Fed-Ex or UPS ground).

Portable Electric Cable Reels

Model LC16-10-11

This durable reel is designed to carry cable permanently wired to its waterproof duplex, which allows the reel to remain on-site as a power source.

A covered duplex receptacle for 3-pronged plugs is standard. A twist lock duplex receptacle can be specified at no extra cost. The reel is supplied with a cam lock brake.

Series CR

These models are compact, lightweight, and have the same rugged construction as our large cable reels. They handle a large capacity of power cable for their size and weight and feature a 3-conductor 30 amp collector ring assembly, which is housed inside the drum. A 6-foot power source lead of 12/3 cable with a 15 amp 3-prong straight blade plug is provided as standard (twist lock plug is optional). Wires from collector ring terminals extend through a grommetted opening in the drum for accessibility. Adjustable friction brake is used to brake the reel.

Rewind:

A crank rewind handle is permanently attached to the disc.



Optional 15-amp 3prong straight blade receptacle recessed in drum.
Part No: 9955.0090



For:

- Extension Cord
- Broadcast Cable

Model LC16-10-11



For:

- Industrial
- Broadcast
- Agricultural
- Fire and Rescue

Series CR

Dimensions and capacities

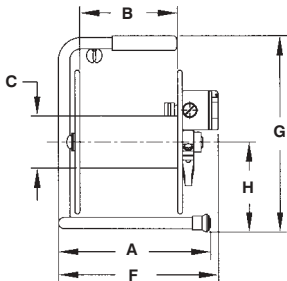

Model LC16-10-11

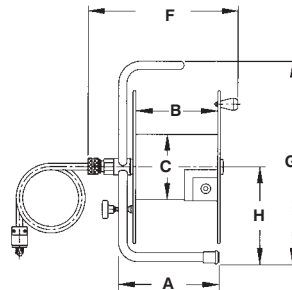
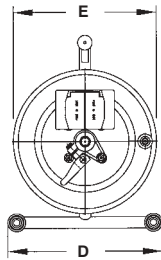

Series CR

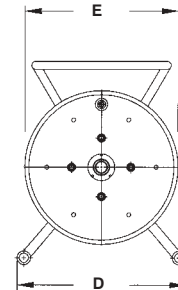

BE SURE TO CHECK DIMENSIONS AND WEIGHTS PRIOR TO ORDERING.

To receive a detailed parts breakdown drawing for Series LC, request ISO 120, for Series CR request ISO 156.

Cable Capacity of Reel feet m.	Model Number	Reel Dimensions inches mm.										Approx. Weight lb. kg.		
		A	B	C	D	E	F	G	H	NET	SHIP			
Gauge/Number of Conductors														
16/3 14/3 12/3														
O.D. (in)	.39 .53 .60	A	B	C	D	E	F	G	H	NET	SHIP			
O.D. (mm)	10 13 15													
275 125 100	LC16-10-11	11.75	7.5	4.5	11.88	10.75	12.25	15	6.88	11	14*			
84 38 30		298	190	114	302	273	311	381	175	5	6			
400 200 150	CR16-14-16	9.25	7.5	6	15.5	14	14.5	18.5	8.88	24	30*			
122 61 46		235	190	152	394	356	368	470	226	11	14			
650 300 250	CR16-17-18	9.25	7.5	6	15.5	16.5	14.5	18.5	8.88	26	30*			
198 91 76		235	190	152	394	419	368	470	226	12	14			

Specifications subject to change.

*When shipped as parcel package (via Fed-Ex or UPS ground).

Hannay Reels, Inc. Telephone 518-797-3791
TOLL FREE 1-877-GOREELS

FAX 1-800-REELING (733-5464) USA
FAX 518-797-3259 (International)

www.hannay.com
reels@hannay.com

Portable Hose Reels on Wheels

To handle 1/2" through 1" I.D. hose.

Hannay Hose Reel Models 1100 and AT1200 are designed for portable use in grounds maintenance by the restaurant, fast food, hotel and other industries.

Hannay portable reels get to and from the job fast. Pickup and storage are quick and neat, keeping hose safely out of the way while minimizing wear and tear.

Models 1100 and AT1200 are continuous flow reels with swivel joint inlet, fluid hub and outlet riser.

Model 1100 comes with cam lock brake.

Model AT1200 comes with pneumatic tires and spring tension brake.

Rewind:

Direct crank rewind. Models 1100 and AT1200 have a permanently attached crank.

Inlet:

Model 1100 – standard inlet is 90° ball bearing swivel joint with 1/2" female NPT threads.

Model AT1200 – standard inlet is 90° balance pressure swivel joint with 1" female NPT threads.

Outlet:

Model 1100 and AT1200 – standard outlet is female NPT threads.

Other sizes and/or threads, including male GHT threads, can be furnished and must be specified.

Prefix GH to model number when ordering garden hose thread, e.g., GHAT1200.

Operating Pressures & Temperatures:

Model 1100 operates at pressures to 3000 psi (207 bar) and temperatures from +20° F to +400° F (-7° C to +204° C).

Model AT1200 operates at pressures to 1000 psi (69 bar) and temperatures from -20° F to +225° F (-29° C to +107° C).

Reels to operate at other pressures and temperatures can be furnished at extra cost.

For:

- Grounds Maintenance
- Restaurants
- Home Use



Model 1100 Model AT1200
Shown with GH Option

Dimensions and capacities

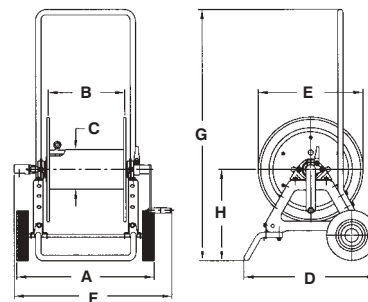

Model 1100

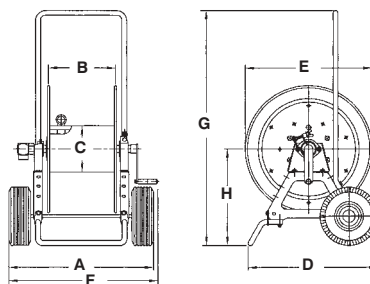

Model AT1200

NOTICE: A FLEXIBLE CONNECTOR MUST BE USED BETWEEN THE INLET PIPE AND THE INLET SWIVEL JOINT. BE SURE TO CHECK DIMENSIONS AND WEIGHTS PRIOR TO ORDERING.

To receive a detailed parts breakdown drawing for Model 1100, request ISO 48, for Model AT1200, request ISO 87.

Hose Capacity of Reel						Model Number	Reel Dimensions								Approx. Weight	
feet m.							inches mm.								lb.	kg.
I.D. (in)	3/8"	1/2"	5/8"	3/4"	1"	A	B	C	D	E	F	G	H	NET	SHIP	
I.D. (mm)	10	13	16	19	25											
O.D. (in)	3/4"	7/8"	1"	1 9/32"	1 9/16"											
O.D. (mm)	19	22	25	33	40											
	300	200	150	-	-	1100	21.5	12	6	22	16.5	24.62	39	13.81	47	50*
	91	61	46	-	-		546	305	152	559	419	625	991	351	21	23
	-	350	250	150	100	AT1200	24.88	11.5	8	23	23	26.5	40	17.25	84	91*
	-	107	76	46	30		632	292	203	584	584	673	1016	438	38	41

Specifications subject to change.

*When shipped as parcel package (via Fed-Ex or UPS ground) – some assembly required.

Portable Storage Reels on Wheels

Models C1150 and ATC1250

These direct crank rewind reels are equipped with one-piece foot, rubber tires, and removable steel handlebar for long-term shipping and storage.

Model C1150 – For storing cable, hose or rope. A 7/8" x 1 3/4" (22.2 mm x 44.4 mm) opening in the drum permits the cable end to be inserted to initiate winding. This model supplied with a cam lock brake.

Model ATC1250 – A larger version of the C1150 model with pneumatic tires and a 4" x 5 1/2" (101.6 mm x 139.7 mm) drum opening. This model supplied with a spring tension brake.

For:

- Industrial Maintenance
- Construction
- Agriculture
- Grounds Maintenance



Model C1150



Model ATC1250

NOTE: THESE STORAGE REELS HAVE NO LIVE CONNECTIONS.

Dimensions and capacities

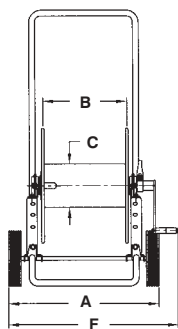

Model C1150

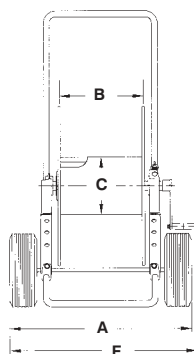
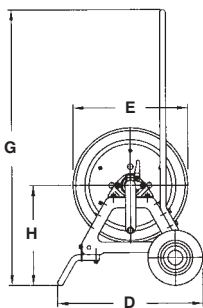

Model ATC1250

BE SURE TO CHECK DIMENSIONS AND WEIGHTS PRIOR TO ORDERING.

To receive a detailed parts breakdown drawing for Model C1150, request ISO 48, for Model ATC1250, request ISO 87.

Cable Capacity of Reel <u>feet</u> m.	Model Number	Reel Dimensions <u>inches</u> mm.										Approx. Weight <u>lb.</u> kg.		
		A	B	C	D	E	F	G	H	NET	SHIP			
Gauge/Number of Conductors														
16/3	14/3	12/3	10/3											
O.D. (in)	.390	.530	.600	.690										
O.D. (mm)	10	14	15	18										
	1100	500	400	300										
	335	152	122	91	C1150	21.5	12	6	22	16.5	24.25	39	13.81	44
						546	305	152	559	419	616	991	351	20
	1800	950	750	550										
	549	290	229	168	ATC1250	24.88	11.5	8	23	23	26.5	40	17.25	82
						632	292	203	584	584	673	1016	438	37

Specifications subject to change.

Notes:

When ordering C1150 and ATC1250, specify model number, O.D., length and weight of cable, hose, etc.

*When shipped as parcel package (via Fed-Ex or UPS ground) – some assembly required.

Portable Cable Reel on Wheels

Model 1300.

This direct crank rewind reel is equipped with one-piece front foot, rubber tires and removable steel handlebar. An adjustable spring drag device is used to brake the reel. A 6-foot power source lead of 10/3 cable with a 15 amp 3-prong straight blade is provided as standard (twist lock plug is optional). Assemblies with additional conductors are available at extra cost and must be specified.

Rewind:

Direct rewind crank is permanently attached to axle.

For:

- Industrial Maintenance
- Construction
- Agriculture
- Broadcast
- Grounds Maintenance



Model 1300

Dimensions and capacities

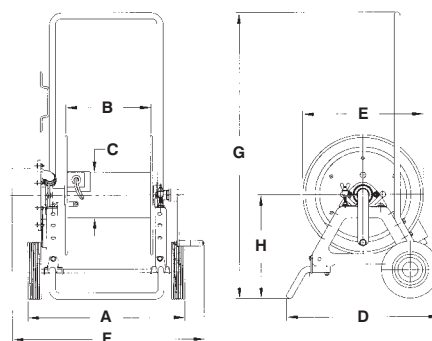

Model 1300

BE SURE TO CHECK DIMENSIONS AND WEIGHTS PRIOR TO ORDERING.

To receive a detailed parts breakdown drawing for Model 1300, request ISO 189.

Cable Capacity of Reel <u>feet</u> m.	Model Number	Reel Dimensions <u>inches</u> mm.									Approx. Weight <u>lb.</u> kg.		
		A	B	C	D	E	F	G	H	NET	SHIP		
Gauge/Number of Conductors													
		14/3	12/3	10/3									
O.D. (in)		.53	.60	.69									
O.D. (mm)		14	15	18									
		500	400	300	1300	21.5	12	6	22	16.5	26.88	39	13.81
		152	122	91		546	305	152	559	419	683	991	351
												50	84*
												23	38

Specifications subject to change.

*When shipped as parcel package (via Fed-Ex or UPS ground) – some assembly required.

Steel hand truck

Model 4300. For portability of hose and cable reels.

Tubular steel hand truck is equipped with 4" x 16" O.D. pneumatic tires for use with many hose or cable reels. The reel you specify is permanently attached to the truck frame and is shipped as a single unit. Overall dimensions will vary according to the reel model used. Hand truck is finished in the same color you specify for the reel. To order give complete model number and specifications for the reel you require and specify that the reel is to be factory installed on Model 4300 hand truck. Specify if reel spool axis is to be perpendicular to truck axle (as shown) or parallel to the truck axle. Hand truck adds 48 lbs. (22 kg.) to weight of reel model.

Note: Truck is also sold separately. Maximum reel size dimensions when installed on hand truck:

A=32" (812.8 mm), E=32" (812.8 mm),
B=27" (685.8 mm).



4300 truck with reel attached

Cable Conversions

Power/Control Cable

Wire Size (AWG)/ Conductors	Area (Per Conductor)	
	Circ. Mils	Sq. mm
16/3	2,600	1.3
14/3	4,100	2.1
12/3	6,500	3.3
10/3	10,500	5.3
8/3	16,800	8.5



From ballfields and apartment complexes to restaurants and schools, Hannay portable spray reels make groundskeeping safer, easier and more efficient.

Hannay portable hose and cable reels put you on the go.

Hannay's portable reels are lightweight for easy portability but are constructed to the same high standards as all Hannay reels. As the world's leading manufacturer of hose and cable reels, Hannay constructs all reels to high standards. Our portable reels come in a range of sizes and are used in a variety of applications, including broadcasting, construction, industrial maintenance and repair, grounds and lawn maintenance, and fire and rescue. You can rely on Hannay's portable reels to get you in service quickly.

To order Hannay Reels

Please refer to our Ordering Guide & Accessory Catalog. For more information on our 2700 standard models of hose and cable reels, please ask about specific product catalogs.

Other Hannay Catalogs available are: Audio Video, Aviation Refueling, Cable, Firefighting, LP Gas, Lube, Petroleum Delivery, Pressure Wash, Spray, Stainless, Triad Rescue, Welding and Ordering Guide & Accessory Catalog.

Available from:



Hannay's rugged portable hose reels are the natural choice for a wide range of outdoor maintenance activities.



Lightweight, durable Hannay portable reels bring power right to your job site while protecting valuable electrical cable from damage.



553 State Route 143
Westerlo, NY 12193-0159
Telephone 518-797-3791
TOLL FREE 1-877-GO REELS
FAX 1-800-REELING (733-5464) USA

OR
FAX 518-797-3259 (International)
www.hannay.com
reels@hannay.com

WSP 5M 03/03

H-9421-POR
Rev. 6